

1. General Description

The ARF2002 is a low noise amplifier operating at 500MHz-6000MHz, power supply +5V operation, at 70mA working current, can provide 22dB gain, OP1dB 22.5dBm, noise figure typical value of 0.68dB. The ARF2002 port impedance is 50 Ω.

2. Features

8 Pin 2X2 mm DFN Package

0.5GHz to 6GHz operation

NF ≤ 0.85dB across 0.5GHz to 5GHz

>20dB gain across 0.5GHz to 5GHz

>33.5dBm OIP3 @ 70mA IDD, 2.6GHz

Shut-down mode pin with 1.8V TTL logic

Supply voltage: +3V to +5V ; does not require -V_{gg}

Maintains OFF state with high input power drive

Unconditionally stable

3. Applications

LTE / WCDMA / CDMA / GSM / Massive MIMO

Repeaters / DAS

TDD or FDD systems

General Purpose Wireless

4. Functional Block Diagram

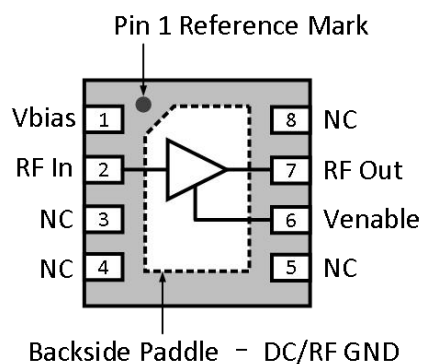

Figure1.

5. Order product model

ARF2002

Directory

1. General Description	1
2. Features	1
3. Applications	1
4. Functional Block Diagram	1
5. Order product model	1
6. Specifications	3
6.1. Electrical Specifications	3
6.2. Handling Ratings	3
6.3. Timing Requirements	4
7. Absolute Maximum Ratings	5
8. Pin Assignments and Description	5
9. VDD=5V Typical Performance	6
10. VDD=5V Performance Plots	6
11. VDD=3.3V Typical Performance	8
12. VDD=3.3V Performance Plots	8
13. Application	10
13.1. PCB Evaluation Board	10
13.2. Evaluation Board BOM	10
14. Package Marking and Outline Dimensions	11
15. PCB Mounting Pattern	12
16. Tape and Reel Information	13
16.1. Carrier and Cover Tape Dimensions	13
16.2. Reel Dimensions	13
17. Notice	14
17.1. Operating protection condition	14
17.2. Operate attention	14
17.3. Solderability	14
17.4. RoHS Compliance	14
17.5. Contact Information	14
Important Notices and disclaimers	15

6. Specifications

6.1. Electrical Specifications

Test Conditions: 50Ω system, VDD=5V and VDD=3.3V, Temp=+25°C, (de-embedded data);

Table1. Electrical Specifications

Parameter	Symbol	Test Conditions	Min	Typ	Max	Units
Frequency Range			0.5		6	GHz
Test Frequency				2.6		GHz
Input Return Loss	S11	VDD=5V		9		dB
		VDD=3.3V		10.5		dB
Output Return Loss	S22	VDD=5V		9		dB
		VDD=3.3V		10		dB
Gain	S21	VDD=5V		22		dB
		VDD=3.3V		22.2		dB
Reverse ISO		VDD=5V		28		dB
		VDD=3.3V		28		dB
Off State Gain		VDD=5V,Pin=20dBm		-21		dB
		VDD=3.3V,Pin=20dBm		-21		dB
OP1dB		VDD=5V		22.5		dBm
		VDD=3.3V		18		dBm
OIP3		VDD=5V,Pout=+5 dBm/tone Δf=1 MHz		33.5		dBm
		VDD=3.3V,Pout=+5 dBm/tone Δf=1 MHz		35		dBm
Noise Figure	NF	VDD=5V		0.68		dB
		VDD=3.3V		0.68		dB
Drain Current		VDD=5V,Venable=0V		70		mA
		VDD=3.3V,,Venable=0V		75		mA
Drain Current		VDD=5V,Venable=5V		2		mA
		VDD=3.3V,,Venable=5V		2		mA
Venable Current		VDD=5V,Venable=5V		400		uA
		VDD=3.3V,,Venable=5V		250		uA

6.2. Handling Ratings

Table2. Handling Ratings

Symbol	Parameter	Min	Typ	Max	Units
T _{STG}	Storage temperature range	-65		+150	°C
V _{ESD}	Human body model (HBM)		Class 1B		V
	Charged device model (CDM)		Class 3C		V

6.3. Timing Requirements

Table3. Timing Requirements

Parameter	Conditions	Min	Typ	Max	Units
Switching Time OFF	VDD=5V or VDD=3.3V		100		ns
Switching Time ON	VDD=5V or VDD=3.3V		100		ns

Table4.Absolute Maximum Ratings

7. Absolute Maximum Ratings

Stresses beyond those listed under Absolute Maximum Ratings may cause permanent damage to the device.Exposure to absolute-maximum-rated conditions for extended periods may affect device reliability.

Parameter	Min	Typ	Max	Units
DC Supply Voltage (VDD)	0		7	V
DC Control Voltage	0		6	V
RF Input Power (Pin), CW, 50ohms, T=25°C			30	dBm
RF Input Power (Pin), CW, Off State, T=25°C			30	dBm
Operating Temperature	-40		105	°C

8. Pin Assignments and Description

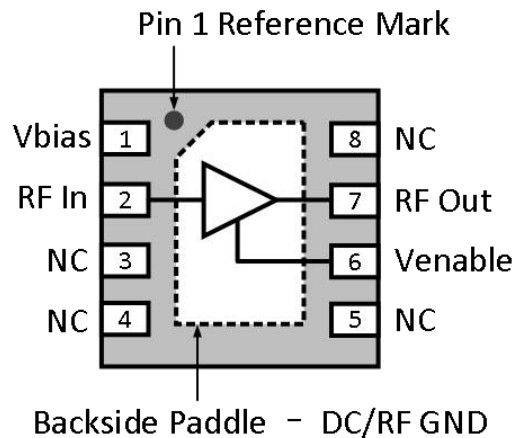

Figure2. Pin Assignments

Table5. Description

Pin No.	Mnemonic	Description
1	Vbias	Setting the Icq bias point for the device.
2	RFIN	RF Input pin, DC Block is required.
3, 4, 5, 8	NC	No electrical connection. Provide grounded land pads for PCB mounting integrity.
6	Venable	A high voltage ($\geq 1.1V$) turning off the device.
7	RFOUT	RF output pin.
Backside Paddle	DC/RF GND	Use recommended via pattern to minimize inductance and thermal resistance.

9. VDD=5V Typical Performance

Test Conditions: 50Ω system, VDD=5V, Temp=+25°C;

Table6. Typical Performance

Parameter	Conditions	Units	Typical					
Frequency		GHz	0.6	1.9	2.6	3.5	4.2	5
Input Return Loss		dB	13	12	9	11	12	17
Output Return Loss		dB	10	9.5	9	9	10	9
Gain		dB	24.5	23.0	22	21	20.5	20.5
OP1dB		dBm	23	23	23	22.8	22.5	22
OIP3	Pout=+5 dBm/tone Δf=1 MHz	dBm	36	35	33.5	33	33	32
Noise Figure		dB	0.6	0.62	0.68	0.72	0.77	0.85

10. VDD=5V Performance Plots

Test Conditions: 50Ω system, VDD=5V, Temp=+25°C;

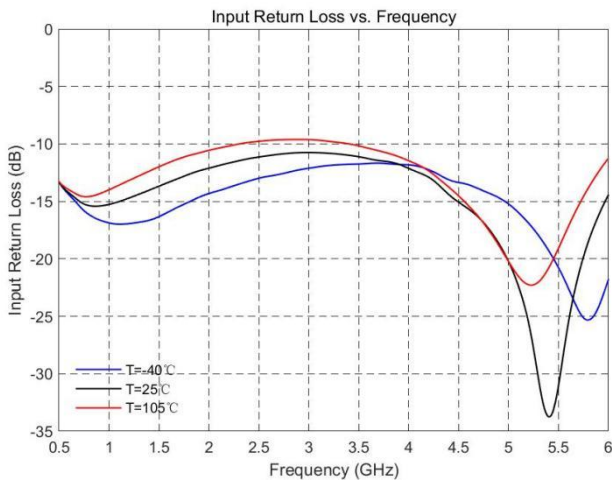

Figure3.

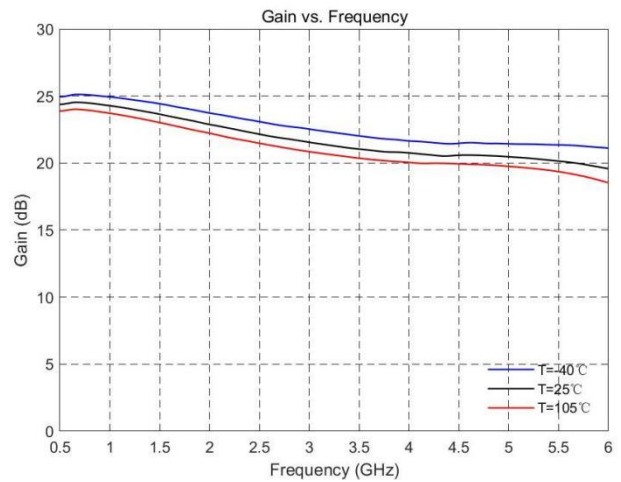

Figure4.

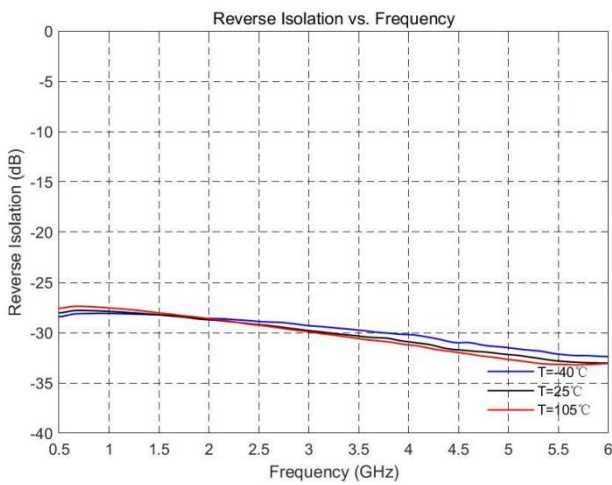

Figure5.

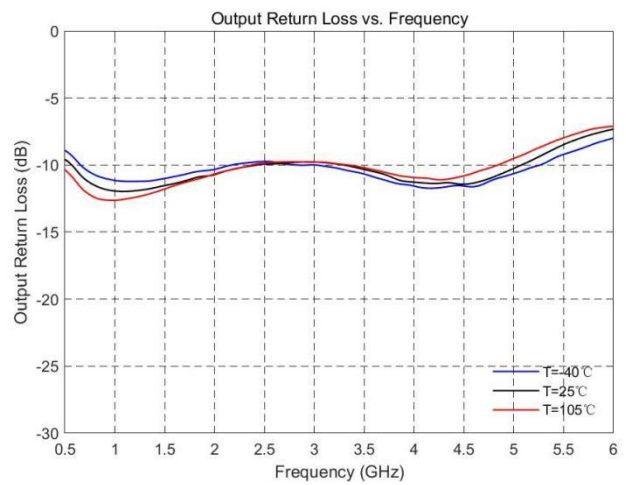

Figure6.

VDD=5V Performance Plots (Cont.)

Test Conditions: 50Ω system, VDD=5V, Temp=+25°C;

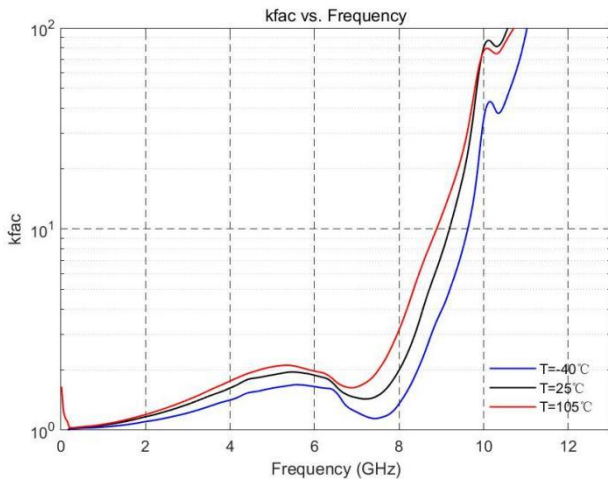

Figure7.

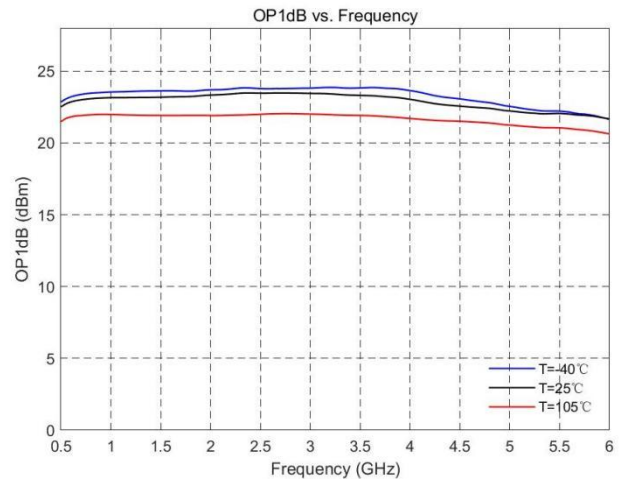

Figure8.

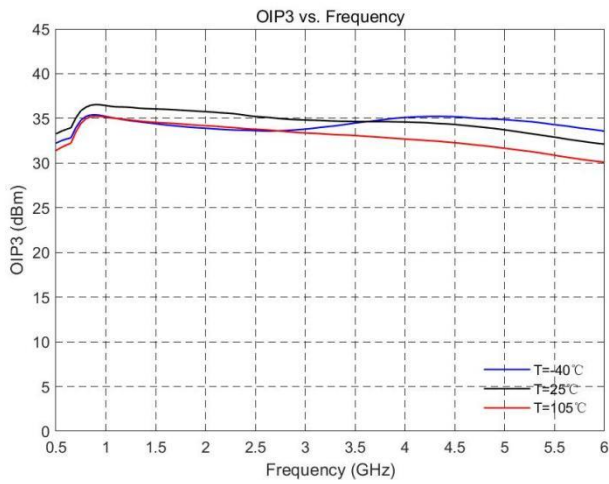

Figure9.

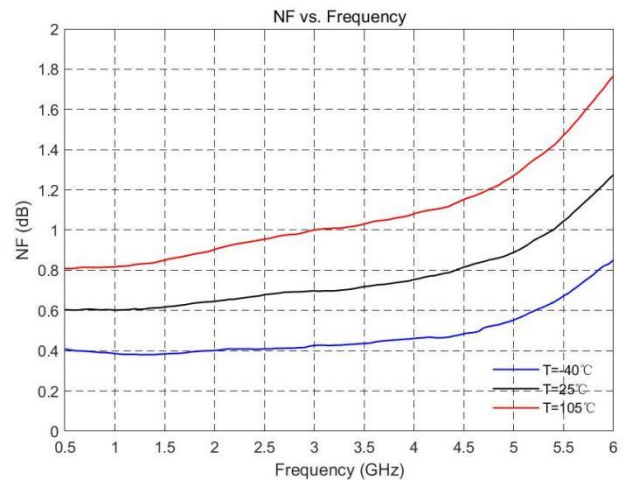

Figure10.

11. VDD=3.3V Typical Performance

Test Conditions: 50Ω system, VDD=3.3V, Temp=+25°C;

Table7. Typical Performance

Parameter	Conditions	Units	Typical					
Frequency		GHz	0.6	1.9	2.6	3.5	4.2	5
Input Return Loss		dB	10.5	12	10.5	11	12	15
Output Return Loss		dB	9	11	10	11	12	13
Gain		dB	24.5	23	22.2	21.4	21	20.8
OP1dB		dBm	18.5	18	18	18.5	18.3	17.5
OIP3	Pout=+5 dBm/tone Δf=1 MHz	dBm	34	35	35	34.5	35	35
Noise Figure		dB	0.60	0.63	0.68	0.72	0.77	0.85

12. VDD=3.3V Performance Plots

Test Conditions: 50Ω system, VDD=3.3V, Temp=+25°C;

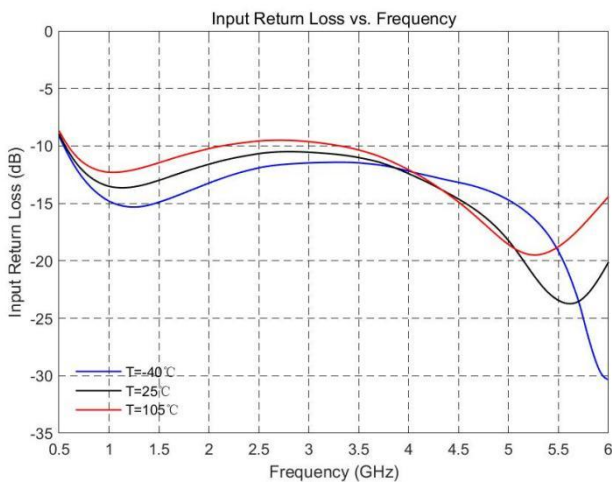

Figure11.

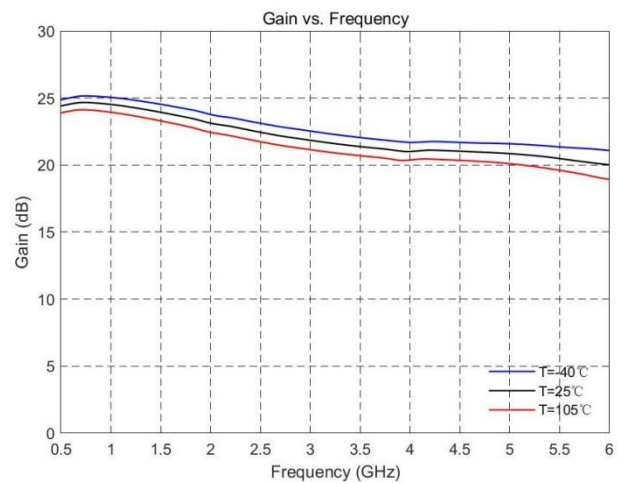

Figure12.

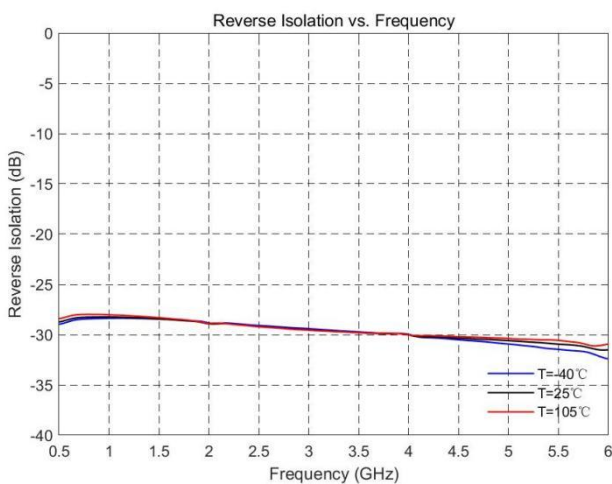

Figure13.

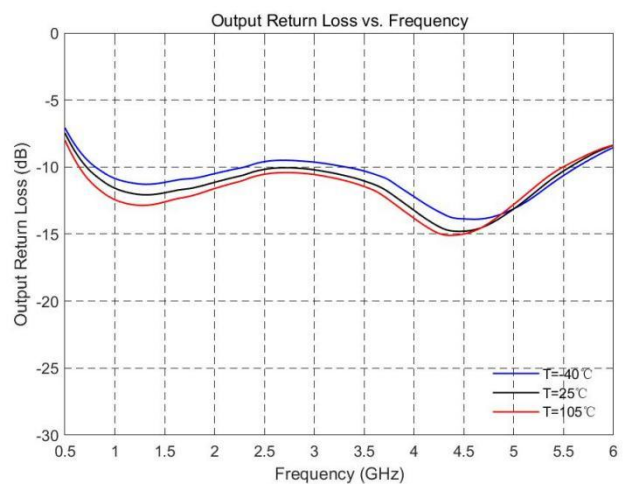

Figure14.

VDD=3.3V Performance Plots (Cont.)

Test Conditions: 50Ω system, VDD=3.3V, Temp=+25°C;

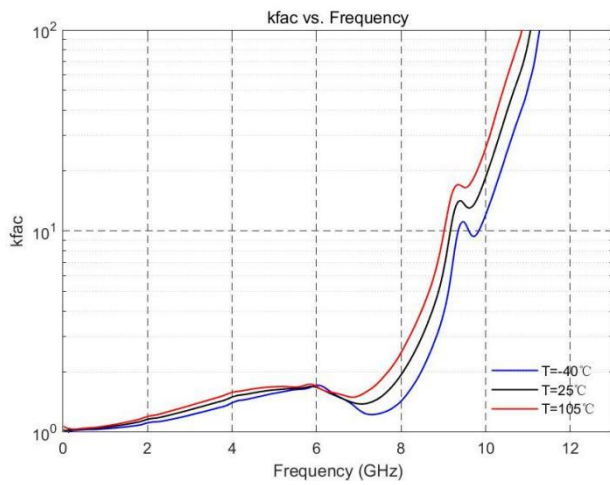

Figure15.

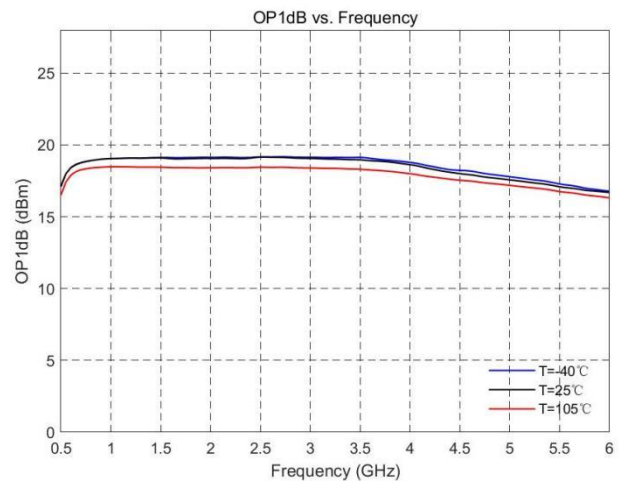

Figure16.

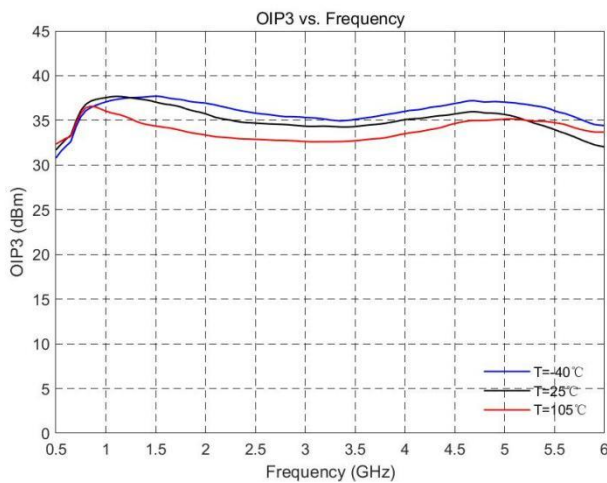

Figure17.

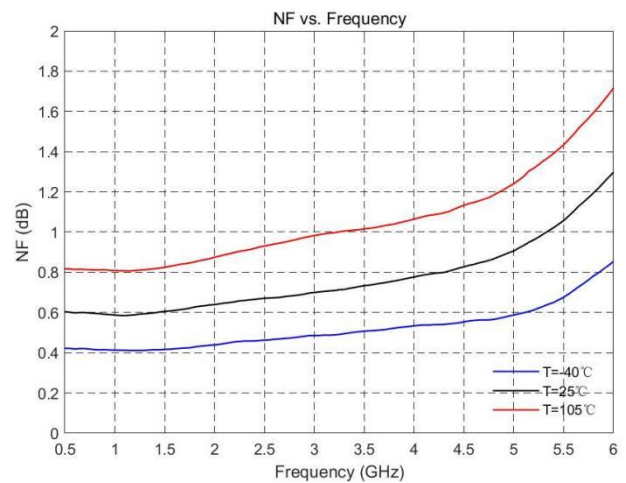

Figure18.

13. Application

13.1. PCB Evaluation Board

The ARF2002 device is typically placed in a system like the one shown below Figure19.

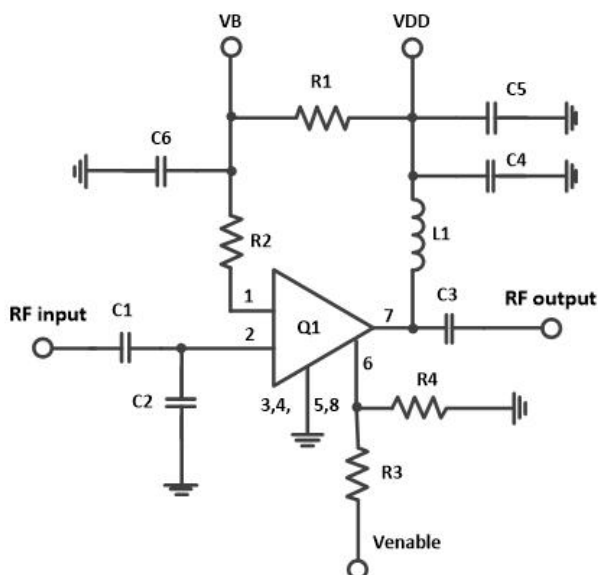

Figure19.

13.2. Evaluation Board BOM

Table8. Bill of Materials for Evaluation PCB

Item	Conditions	Value	Manuf.	Part Num.
PCB	N/A	N/A	ARF	ARF2002-EVB
Q1	N/A	N/A	ARF	ARF2002
R1	N/A	0 Ω	Various	0402
R2	VDD=5V	4.7k Ω	Various	0402
	VDD=3.3V	1.0k Ω	Various	0402
R3	N/A	0 Ω	Various	0402
R4	N/A	N/A	N/A	N/A
L1	N/A	22nH	Murata	LQW15
C1	VDD=5V	1uF	Various	0402
	VDD=3.3V	22pF	Various	0402
C2	N/A	0.4pF	Various	0402
C3	N/A	15pF	Various	0402
C4	N/A	100pF	Various	0402
C5	N/A	1uF	Various	0402
C6	N/A	100nF	Various	0402

14. Package Marking and Outline Dimensions

- 1) All dimensions are in millimeters.
- 2) DFN 8 pin 2x2x0.85mm Package.
- 3) Marking: Part number - 2002
Lot code - XXXX
- 4) Coplanarity applies to the exposed heat sink slug as well as the terminals.
- 5) The package thermal pad must be soldered to the printed circuit board for thermal and mechanical performance.

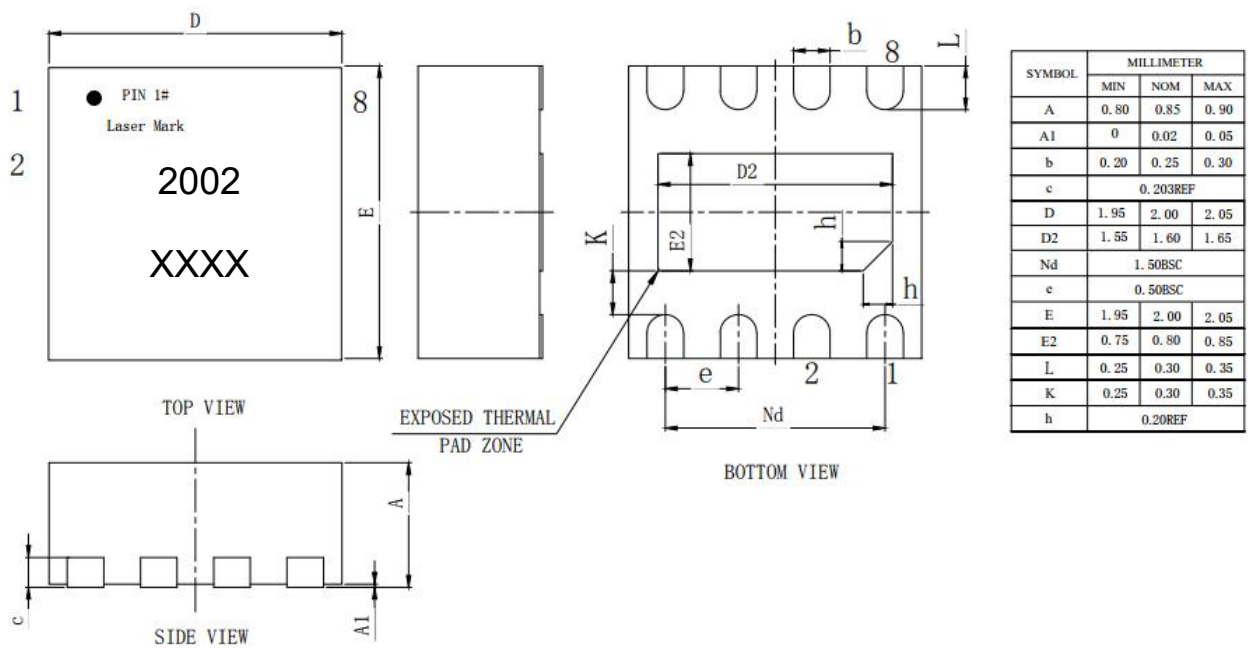

Figure20. Package Marking and Outline Dimensions

15. PCB Mounting Pattern

- 1) All dimensions are in millimeters.
- 2) Vias are required under the backside paddle of this device for proper RF/DC grounding and thermal dissipation.

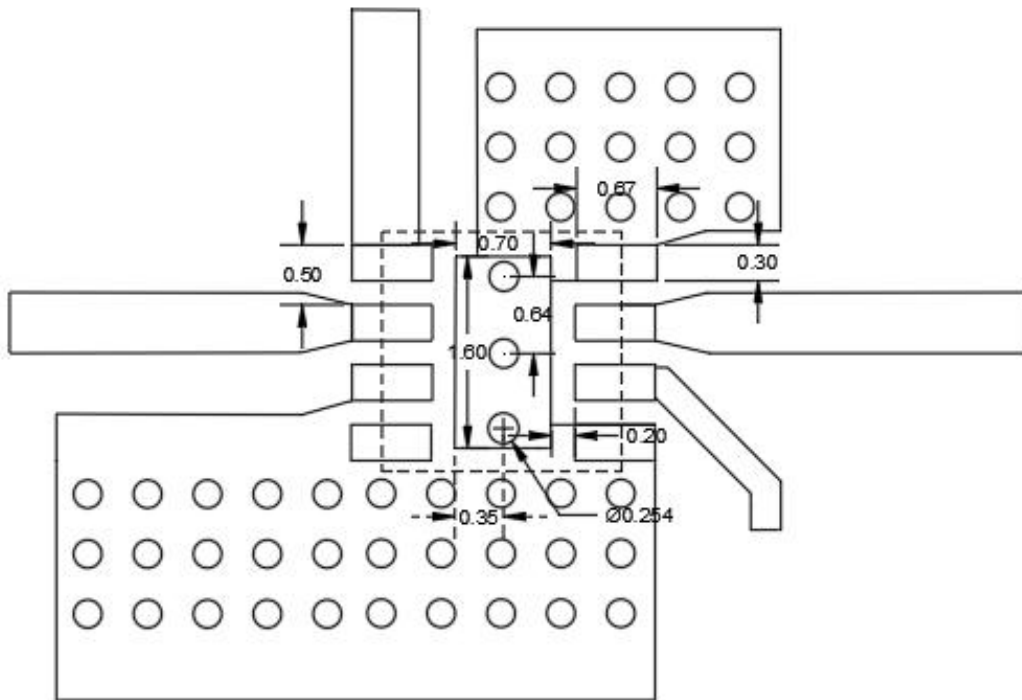

Figure21.PCB Layout Footprint (Top View)

16. Tape and Reel Information

16.1. Carrier and Cover Tape Dimensions

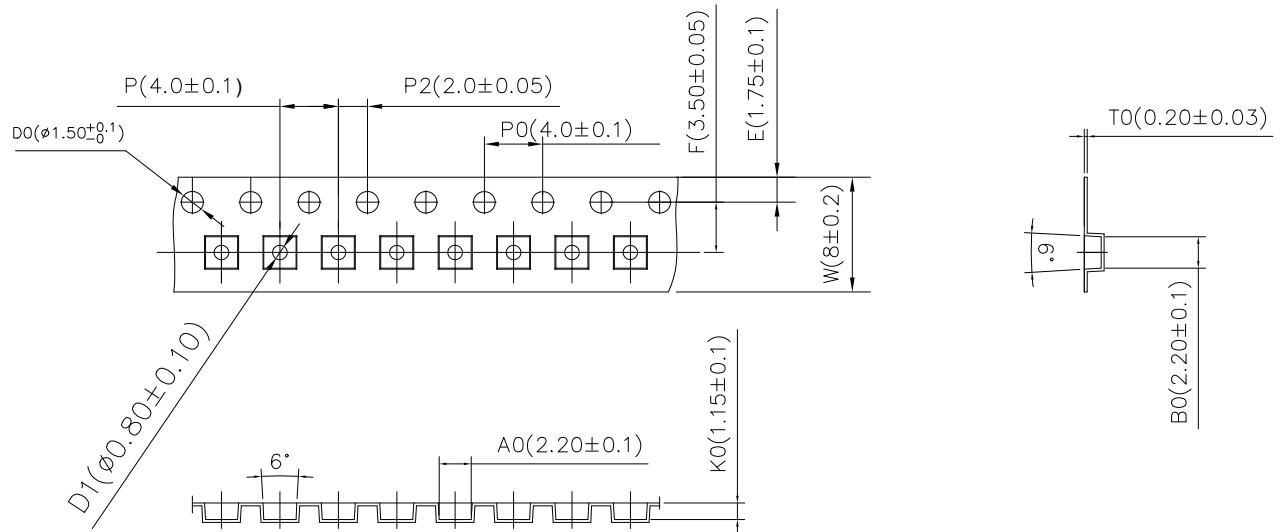

Figure22.Carrier and Cover Tape Dimensions

16.2. Reel Dimensions

Standard T/R size=3,000 pieces on a 7" reel.

17. Notice

17.1. Operating protection condition



Devices and circuit boards may be undetected. Although this product has an ESD protection circuit, the device may be damaged when encountering high energy ESD. Therefore, appropriate ESD prevention measures should be taken to avoid deterioration of device performance or loss of function.

17.2. Operate attention

1. Must be placed in a container with electrostatic protection function, dry environment, conditions permit the best storage nitrogen environment.
2. Please strictly comply with the ESD protection requirements to avoid electrostatic damage.
3. Use vacuum clamps or tweezers to avoid tools or fingers touching the product surface.

17.3. Solderability

Compatible with lead-free (260 °C maximum reflow temperature) soldering processes.

17.4. RoHS Compliance

This product is compliant with the EU RoHs2.0, EU Directive 2015/863.

17.5. Contact Information

Telephone: 65-31580333 / 65-80673575

Email: sales@arf-semi.com

Website: www.arf-semi.com

Address: 3E Gambas Crescent Singapore 757033

Important Notices and disclaimers

The information provided in this document is intended as a guide only and shall not in any event be regarded as a guarantee of conditions, characteristics or performance. ARF does not assume any liability arising out of the application or use of any product described herein, including but not limited to any personal injury, death, or property or environmental damage. No licenses, patent rights, or any other intellectual property rights is granted or conveyed. ARF reserves the right to modify without notice. All rights reserved.